

COMMUNICATION

Landis+Gyr

CU-G20, G21, G22

TECHNICAL DATA



Designs

Type survey

Type	GSM-Modem	RS232	RS485	CS+
CU-G20	●			
CU-G21	●	●		●
CU-G22	●		●	●

Supported Communication Protocols

IEC 62056-21 and *dlms*

Fitting

direct in meter (ZxD300/400xT or ZxQ)
in CU adapter CU-ADP1 (for other meters)

Power Consumption

Maximum Active/Apparent Power	3.0 W / 5.5 VA
-------------------------------	----------------

GSM Modem

Standard	ETS 300 607-1 / EN 301 419-1
approvals	GSM Phase 2/2+, R&TTE, GCF

Functions

time window and time master functions
SMS-forwarding of alarm messages (only if fitted in meter)
modem initializing and data flow control
automatic modem reset
communication monitoring

GSM Module

type Siemens Cellular Engine TC35i
frequency bands dual band EGSM900 and GSM1800
output power
- 2 W/class 4 at EGSM900
- 1 W/class 1 at GSM1800

SIM Card

SIM 1.8 / 3 V	exchangeable from outside
---------------	---------------------------

RS232 Interface

Only Present on Type CU-G21

asymmetric, serial, asynchronous, bi-directional interface (3-wire design)
standard EIA RS232-C / CCITT V.24
maximum transmission rate 57'600 bps
maximum line length 15 m

RS485 Interface

Only Present on Type CU-G22

asymmetric, serial, asynchronous, bi-directional interface (master or slave depending on parameterization)
standard ISO-8482
maximum number of slaves 31
maximum transmission rate 57'600 bps
max. line length depending on environment / cable
- up to 250 m at max. 57'600 bps+max. 31 Slaves
- up to 550 m at max. 38'400 bps+max. 31 Slaves
- up to 1000 m at max. 19'200 bps+max. 15 Slaves

CS Interface

Only Present on Types CU-G21 and CU-G22
 serial, bi-directional current interface
 active or passive
 standard IEC 62056-21 / DIN 66258
 maximum number of slaves 4
 maximum transmission rate 19'200 bps
 maximum line length 3 m

Displays

LED Displays TX, RX, CON
 number of base stations receivable and field strength level (only for GSM operation)
 connection and data flow

Environmental Influences

In General same as for base meter
 exception: temperature range -20 °C to +55 °C

Insulation Strength to Meter

Insulation Strength 4 kV at 50 Hz for 1 min
 insulation spacing at least 6.3 mm

Weight and Dimensions

Weight approx. 100 g
 Width / Height / Depth 65 / 103 / 38 mm

Connections

Terminal Layout

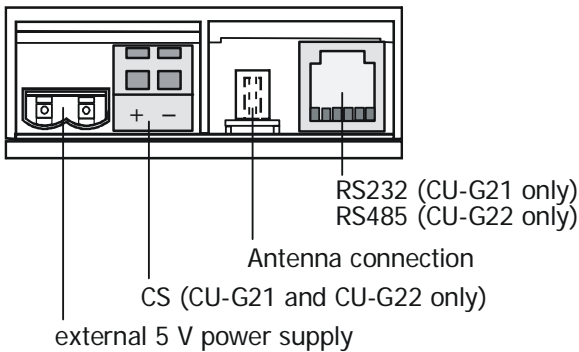

Connection to Meter or CU Adapter

10-pin connector at rear of CU

External 5 V Power Supply (only for ZxD)

2-pin connector; recommended in the following cases for a reliable modem operation:

- meter is connected to less than three phases
- supply voltage phase – phase < 173 V
- supply voltage phase – neutral < 100 V
- meter with auxiliary power supply

CS Interface screwless spring-type terminals

Antenna Connection MCX socket
 tear-off strength < 390 N

RS232 or RS485 Interface RJ12 socket

Pin allocation:	RS232:	RS485:
	1 not used	1 GND
	2 TxD	2 UP (Data a)
	3 GND	3 UN (Data b)
	4 not used	4 UN (Data b)
	5 RxD	5 UP (Data a)
	6 not used	6 GND

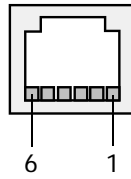

Material

Case polycarbonate

Connection Diagram

Example CU-G21

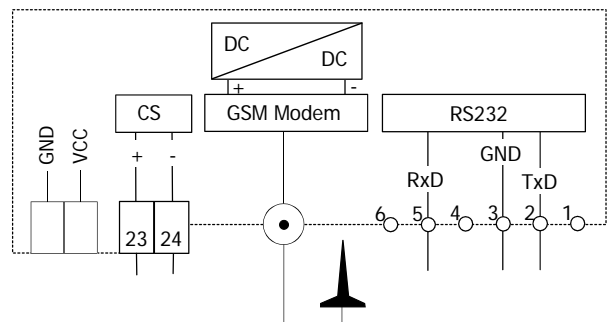

Example CU-G22

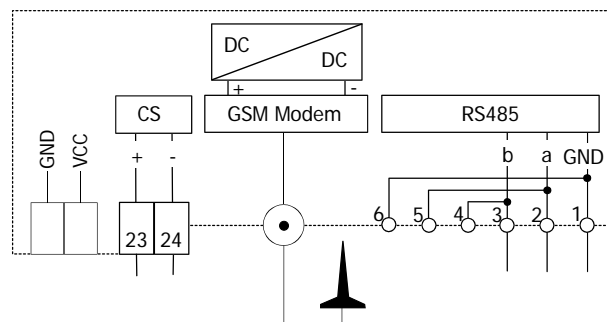

Subject to change without notice.

Landis + Gyr AG

Feldstrasse 1
 CH-6301 Zug
 Switzerland
 Phone: +41 41 935 6000
 www.landisgyr.com

