

COMMUNICATION

Landis+Gyr

CU-P30, P31, P32

TECHNICAL DATA



Designs

Type Survey				
Type	GSM/GPRS Modem	RS232	RS485	CS+
CU-P30	●			
CU-P31	●	●		●
CU-P32	●		●	●

Supported Communication Protocols

- IEC 62056-21 and *dlms*
- TCP/IP
- IPT (according to DIN 43863)

Fitting

directly in meter (ZxD300/400xT or ZxQ)
in CU adapter CU-ADP1 (for other meters)

Power Consumption

Maximum Active/Apparent Power 3.0 W/5.5 VA

GSM/GPRS Modem

Operating Modes GSM or GPRS

GSM operation

- standard ETS 300 607-1/EN 301 419-1
- approvals GSM Phase 2/2+, R&TTE, GCF, CE

GPRS operation

- standard GSM 03.60, Vers. 7.8.0 (GPRS)
- GPRS class 4 (recommended), 10 (maximum)

Functions

time window and time master functions
SMS-forwarding of alarm messages
(only if fitted in meter)
modem initializing and data flow control
automatic modem reset
communication monitoring

GSM/GPRS Module

type Siemens Cellular Engine MC39i
frequency bands dual band EGSM900 and GSM1800
output power
- 2 W/class 4 at EGSM900
- 1 W/class 1 at GSM1800

SIM Card

SIM 1.8/3 V exchangeable from outside

CS Interface

Only present on Types CU-P31 and CU-P32

serial, bi-directional current interface
active or passive

standard IEC 62056-21/DIN 66258
maximum number of slaves 4
maximum transmission rate 19'200 bps
maximum line length 3 m

RS232 Interface

Only present on Type CU-P31

asymmetric, serial, asynchronous, bi-directional
interface (3-wire design)
standard EIA RS232-C/CCITT V.24
maximum transmission rate 57'600 bps
maximum line length 15 m

RS485 Interface

Only present on Type CU-P32

asymmetric, serial, asynchr., bi-directional interface
(master or slave depending on parameterization)

standard ISO-8482

maximum number of slaves 31

maximum transmission rate 57'600 bps

max. line length

- up to 250 m at max. 57'600 bps, max. 31 Slaves

- up to 550 m at max. 38'400 bps, max. 31 Slaves

- up to 1000 m at max. 19'200 bps, max. 15 Slaves

Displays

LED Displays TX, RX, CON

number of base stations receivable and field strength level (for GSM and GPRS operation)

connection and data flow

Environmental Influences

In General same as for base meter

exception: temperature range -20 °C to +55 °C

Insulation Strength to Meter

Insulation Strength 4 kV at 50 Hz for 1 min

insulation spacing at least 6.3 mm

Weight and Dimensions

Weight approx. 100 g

Width / Height / Depth 65 / 103 / 38 mm

Connections

Connection to Meter or CU Adapter

10-pin connector at rear of CU

External 5 V Power Supply (only for ZxD)

2-pin connector; recommended in the following cases for a reliable modem operation:

- meter is connected to less than three phases
- supply voltage phase – phase < 173 V
- supply voltage phase – neutral < 100 V
- meter with auxiliary power supply

CS Interface screwless spring-type terminals

Antenna Connection MCX socket

tear-off strength < 390 N

Terminal Layout

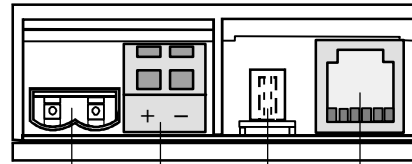

RS232 (CU-P31 only)
RS485 (CU-P32 only)

Antenna connection

CS (CU-P31 and CU-P32 only)

external 5 V power supply

RS232 or RS485 Interface

RJ12 socket

Pin allocation:

RS232:

RS485:

1 not used

1 GND

2 TxD

2 UP (Data a)

3 GND

3 UN (Data b)

4 not used

4 UN (Data b)

5 RxD

5 UP (Data a)

6 not used

6 GND

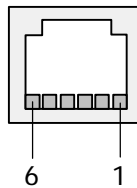

Material

Case

polycarbonate

Connection Diagram

Example CU-P31

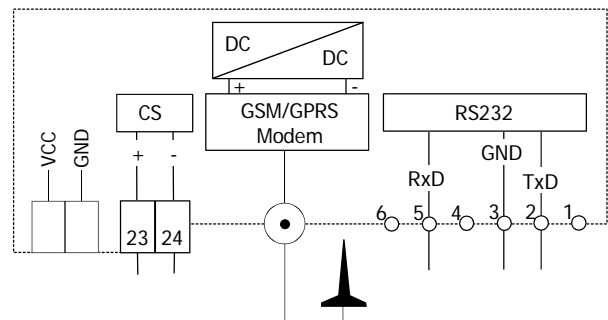

Example CU-P32

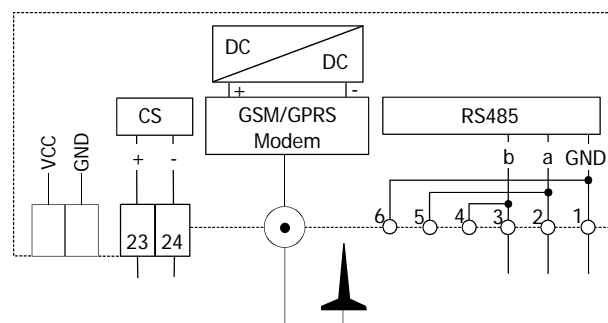

Subject to change without notice.

Landis+Gyr Ltd.

Feldstrasse 1

CH-6301 Zug

Switzerland

Telephone: +41 41 935 6000

www.landisgyr.com

Landis+Gyr+